

DMU330

Ultrasonic sensors with analog and switching output

en 01-2017/02 50135826



Dimensioned drawing

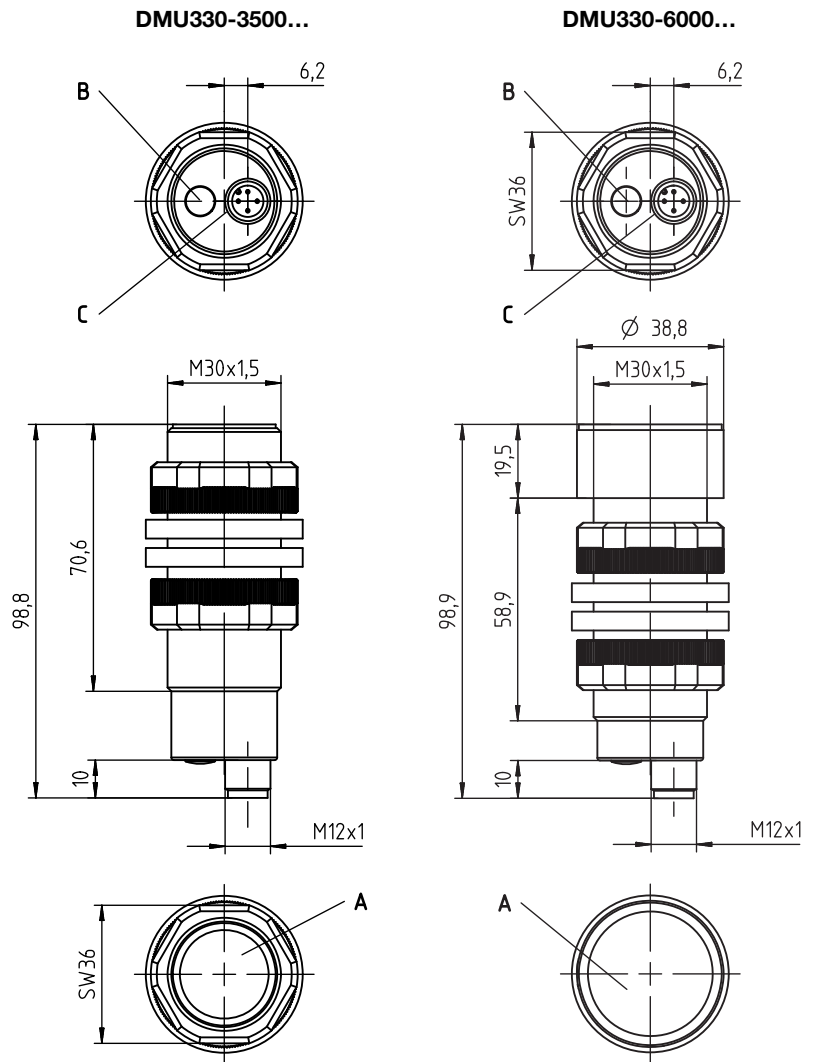

- A Active sensor surface
- B Teach-in button
- C Indicator diodes

Electrical connection

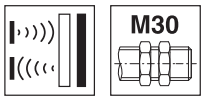
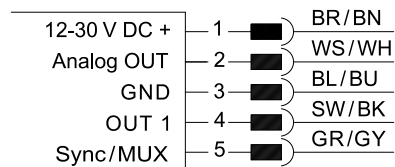

250 ... 3500 mm
350 ... 6000 mm

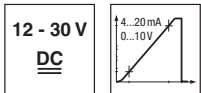

- Function largely independent of surface properties, ideal for detection of liquids, bulk materials, transparent media, ...
- Small dead zone at long scanning range
- 1 analog output 0 ... 10V or 4 ... 20mA
- 1 switching output (PNP or NPN)
- NO/NC function reversible
- **NEW** – Both outputs can easily be taught using a button
- **NEW** – Stable plastic design
- **NEW** – Temperature-compensated scanning range

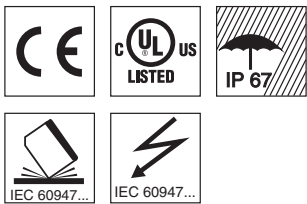

Accessories:

(available separately)

- Mounting systems
- Cables with M12 connector (KD ...)

We reserve the right to make changes • PAL_DMU330_3500_6000_en_50135826.fm

Technical data

Ultrasonic specifications

Scanning range ¹⁾
 Adjustment range
 Ultrasonic frequency
 Typ. opening angle
 Resolution
 Direction of beam
 Reproducibility
 Switching hysteresis
 Analog output accuracy
 Temperature drift ⁵⁾

DMU330-3500.3/...-M12

250 ... 3500mm ²⁾
 250 ... 3500mm
 112kHz
 $\pm 7^\circ$
 5mm
 Axial
 $\pm 0.5\%$ ^{1) 4)}
 1% ⁴⁾
 1% ⁴⁾
 Analog output: $\leq 5\%$,
 Switching output: $\leq 8\%$

DMU330-6000.3/...-M12

350 ... 6000mm ³⁾
 350 ... 6000mm
 75kHz
 $\pm 9^\circ$
 6mm
 Axial
 $\pm 0.5\%$ ^{1) 4)}
 1% ⁴⁾
 1% ⁴⁾
 Analog output: $\leq 5\%$,
 Switching output: $\leq 8\%$

Timing

Switching frequency
 Response time
 Readiness delay

2Hz
 250ms
 ≤ 900 ms (analog output),
 ≤ 500 ms (switching output)

1Hz
 500ms
 ≤ 900 ms (analog output),
 ≤ 500 ms (switching output)

Electrical data

Operating voltage U_B ⁶⁾ 12 ... 30V DC (incl. $\pm 5\%$ residual ripple)
 Residual ripple $\pm 5\%$ of U_B
 Open-circuit current ≤ 50 mA

Analog output

Analog output .../...C... 1 analog output 4 ... 20mA
 .../...V... 1 analog output 0 ... 10V

Load resistance

Current output: $R_L \leq 500\Omega$,
 Voltage output: $R_L \geq 2k\Omega$
 1-point teach: teach in button 2 ... 7s,
 2-point teach: teach in button 7 ... 12s,
 Characteristic curve inversion: teach in button > 12s
 Distance too small: approx. 3.8mA,
 Distance too large: approx. 11V / approx. 21mA

Characteristic curve adjustment

Analog output error signal

Switching output

Switching output / Function .../4... 1 PNP transistor switching output
 OUT 1 (pin 4): NO contact preset

.../2... 1 NPN transistor switching output
 OUT 1 (pin 4): NO contact preset

Output current
 Switching range adjustment

1-point teach: teach-in button 2 ... 7s,
 2-point teach: teach-in button 7 ... 12s
 Teach-in button > 12s

Changeover NO/NC

Indicators

Yellow LED
 Blue LED
 Yellow/green or blue/green LED flashing
 Green LED

OUT1: object detected
 Analog OUT: object detected
 Teach-in / teaching error
 Object within the scanning range

Mechanical data

Housing
 Active surface
 Weight
 Ultrasonic transducer
 Connection type
 Fitting position

Plastic (PBT)
 Epoxy resin, glass fiber reinforced
 140g / 170g
 Piezoceramic ⁷⁾
 M12 connector, 5-pin
 Any

Environmental data

Ambient temp. (operation/storage) $-20^\circ \dots +70^\circ\text{C} / -20^\circ \dots +70^\circ\text{C}$
 Protective circuit ⁸⁾ 1, 2, 3
 VDE protection class III
 Degree of protection IP 67
 Standards applied EN 60947-5-2
 Certifications UL 508, CSA C22.2 No.14-13 ^{6) 9)}

- 1) At 20°C
- 2) Target: 200mm x 200mm plate
- 3) Target: 400mm x 400mm plate
- 4) From end value
- 5) Over the temperature range $-20^\circ\text{C} \dots +70^\circ\text{C}$
- 6) For UL applications: use is permitted exclusively in Class 2 circuits according to NEC
- 7) The ceramic material of the ultrasonic transducer contains lead zirconium titanate (PZT)
- 8) 1=short-circuit and overload protection, 2=polarity reversal protection, 3=wire break and inductive protection
- 9) These proximity switches shall be used with UL Listed Cable assemblies rated 30V, 0.5A min, in the field installation, or equivalent (categories: CYJV/CYJV7 or PVVA/PVVA7)

Diagrams

DMU330-3500.3/...-M12

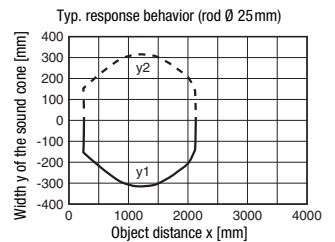
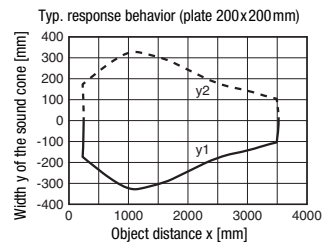

DMU330-6000.3/...-M12

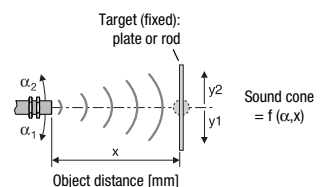
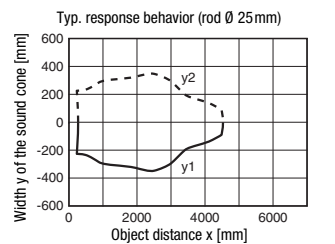
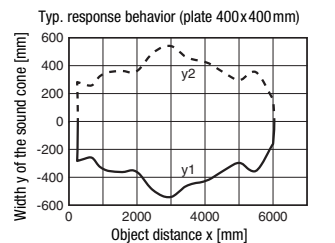

Notes

Observe intended use!

- ⚠ This product is not a safety sensor and is not intended as personnel protection.
- ⚠ The product may only be put into operation by competent persons.
- ⚠ Only use the product in accordance with its intended use.

DMU330

Ultrasonic sensors with analog and switching output

Part number code

D	M	U	3	3	0	-	3	5	0	0	.	3	/	4	V	K	-	M	1	2
---	---	---	---	---	---	---	---	---	---	---	---	---	---	---	---	---	---	---	---	---

Operating principle

HTU Ultrasonic sensor, scanning principle, with background suppression
DMU Ultrasonic sensor, distance measurement
RKU Ultrasonic sensor, retro-reflective ultrasonic sensor

Series

330 330 series, cylindrical short M30 design

Scanning range in mm

3500 250 ... 3500

6000 350 ... 6000

Equipment

.3 Teach button on the sensor

Pin assignment of connector pin 4 / black cable wire (OUT1)

4 PNP output, NO contact preset

P PNP output, NC contact preset

2 NPN output, NO contact preset

N NPN output, NC contact preset

Pin assignment of connector pin 2 / white cable wire (Analog OUT/OUT2)

4 PNP output, NO contact preset

P PNP output, NC contact preset

2 NPN output, NO contact preset

N NPN output, NC contact preset

C Analog output 4 ... 20mA

V Analog output 0 ... 10V

Pin assignment of connector pin 5 / gray cable wire (Sync / MUX)

K Synchronization/multiplex input

Connection technology

M12 M12 connector, 5-pin

Order guide

The sensors listed here are preferred types; current information at www.leuze.com.

	Designation	Part no.
Scanning range / switching output / analog output / teach-in		
250 ... 3500 mm / PNP / current output 4 ... 20mA / teach button	DMU330-3500.3/4CK-M12	50136114
250 ... 3500 mm / PNP / voltage output 0 ... 10V / teach button	DMU330-3500.3/4VK-M12	50136112
250 ... 3500 mm / NPN / current output 4 ... 20mA / teach button	DMU330-3500.3/2CK-M12	50136115
250 ... 3500 mm / NPN / voltage output 0 ... 10V / teach button	DMU330-3500.3/2VK-M12	50136113
350 ... 6000 mm / PNP / current output 4 ... 20mA / teach button	DMU330-6000.3/4CK-M12	50136117

Device functions and indicators – switching output

The sensor has a button for setting switching output **OUT1** and analog output **Analog OUT**. Use the **teach button** to perform the 1-point teach, the 2-point window-teach and to changeover the switching function (NO contact/NC contact). Device status and switching states for **OUT1** are indicated as follows by means of a **yellow LED**:

Switching output OUT1

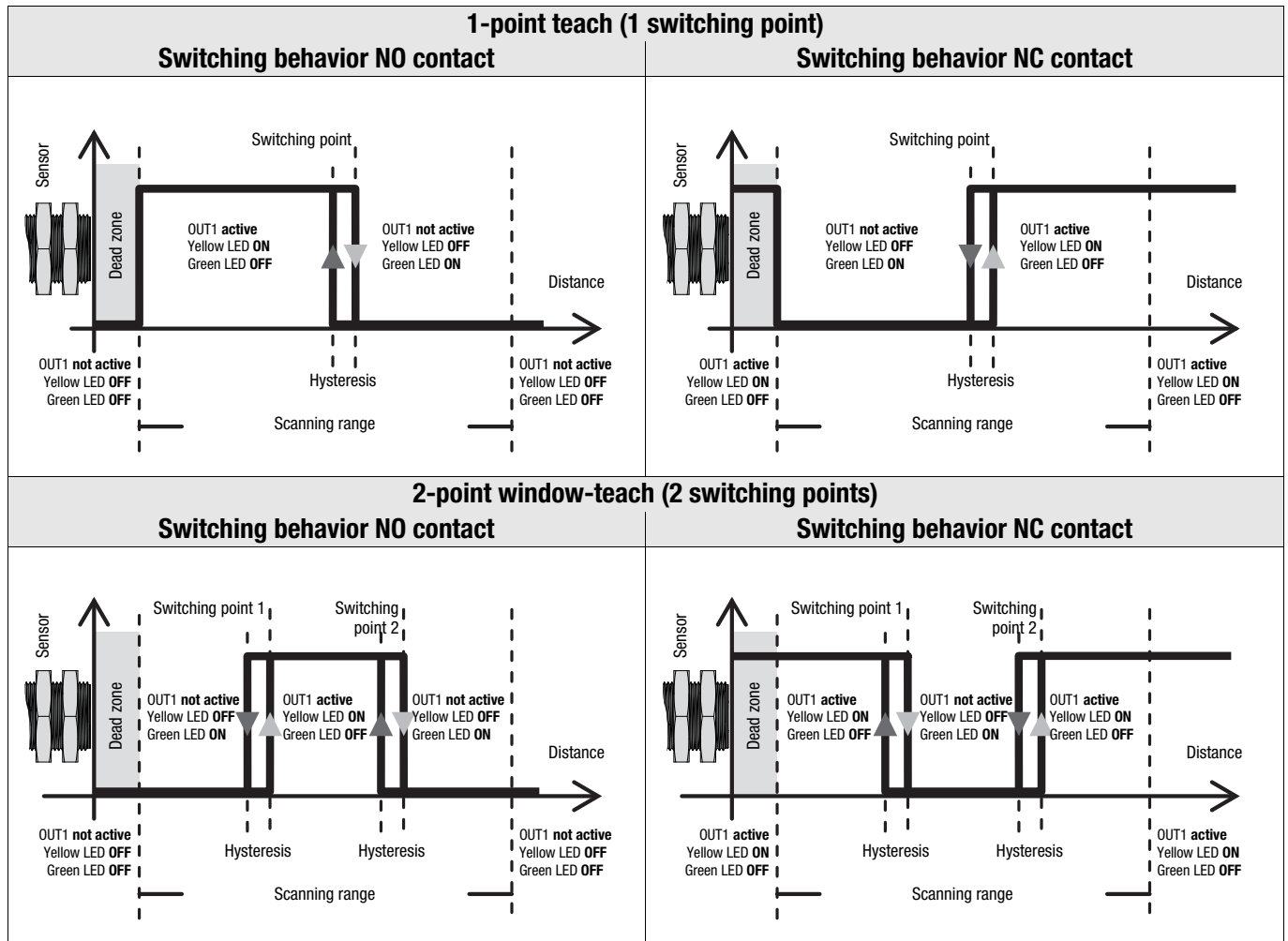

Note!
The switching behavior is not defined in the dead zone.

Switching behavior with 2-point window-teach as a function of the switching function

Switching function configured as	First taught object distance	Second taught object distance	Output switching behavior
NO (normally open)	Close	Far	
	Far	Close	
NC (normally closed)	Close	Far	
	Far	Close	

Adjusting the switching points via the teach button

The switching point of the sensor is set to 3500mm or 6000mm (static 1-point teach) on delivery.

By means of a simple operating procedure, the switching point for the output OUT1 can be individually taught to an arbitrary distance within the scanning range with 1-point teach (static) or 2-point window-teach (static).

Moreover, the output function can be switched from NO contact (NO - normally open) to NC contact (NC - normally closed).

Selecting the output that is to be taught: OUT1 or Analog OUT

1. Press the **teach button** for ≥ 2 s to **activate teach mode**. The **yellow LED (OUT 1) flashes** at 1 Hz.
While in this state, **output OUT 1** can be taught.
2. To teach **output Analog OUT**, **briefly** press the **teach button** again. The **blue LED (Analog OUT)** now flashes at 1 Hz.
While in this state, **output Analog OUT** can be taught.
3. Briefly press the teach button again to toggle between outputs **OUT 1** and **Analog OUT** in this state. The flashing LED indicates which output is ready for teaching:
yellow LED flashing = OUT 1 ready for teaching,
blue LED flashing = Analog OUT ready for teaching.

Teaching output OUT 1

First activate the previously described teach mode for output OUT 1.

1-point teach (static)	2-point window-teach (static) ¹⁾
1. Place object at desired switching distance.	1. First, place object at desired switching distance for switching point 1 .
2. To adjust the output OUT1 , press the teach button for 2 ... 7s until the yellow LED flashes at 3Hz .	2. To adjust the output OUT1 , press the teach button for 7 ... 12s until the yellow and green LEDs flash alternately at 3Hz .
3. Release the teach button to complete the teach event. The current object distance has been taught as the new switching point.	3. Release the button . The sensor remains in teach mode and the LEDs continue to flash.
4. Error-free teach: LED states and switching behavior according to the diagram shown above. Faulty teach (object may be too close or too far away – please note scanning range): green and yellow LEDs flash at 8Hz until an error-free teach event is performed. The affected output is inactive as long as there is a teaching error.	4. Then, place the object at the desired switching distance for switching point 2 . Note: The minimum distance between the switching points is as follows: scanning range of 3500mm: 350mm scanning range of 6000mm: 600mm
	5. Briefly press the teach button again to complete the teach event. The switching window was taught in.
	6. Error-free teach: LED states and switching behavior according to the diagram shown above. Faulty teach (object may be too close or too far away – please note scanning range): green and yellow LEDs flash at 8Hz until an error-free teach event is performed.

1) See table "Switching behavior with 2-point window-teach as a function of the switching function"

Adjusting the switching function (NC/NO) via the teach button

The switching function of the sensor is preset as follows on delivery:

- **OUT 1: NO contact**

The output function can be switched from NO contact (NO - normally open) to NC contact (NC - normally closed) and vice versa. If the switching function is changed, the switching output is changed to the opposite state (toggled).

First activate the previously described teach mode for output OUT 1.

Changeover of the switching function
1. To change the switching function of output OUT 1 , press the teach button for longer than 12s. The current state of output OUT 1 is frozen during the adjustment process.
2. The green and yellow LEDs flash alternately at 3Hz. If the yellow LED is ON afterwards, output OUT 1 functions as a normally open contact (NO) . If the yellow LED is OFF afterwards, output OUT 1 functions as a normally closed contact (NC) .

Device functions – analog output

In measurement operation, the **blue LED** displays the behavior of analog output **Analog OUT**.

Analog output Analog OUT

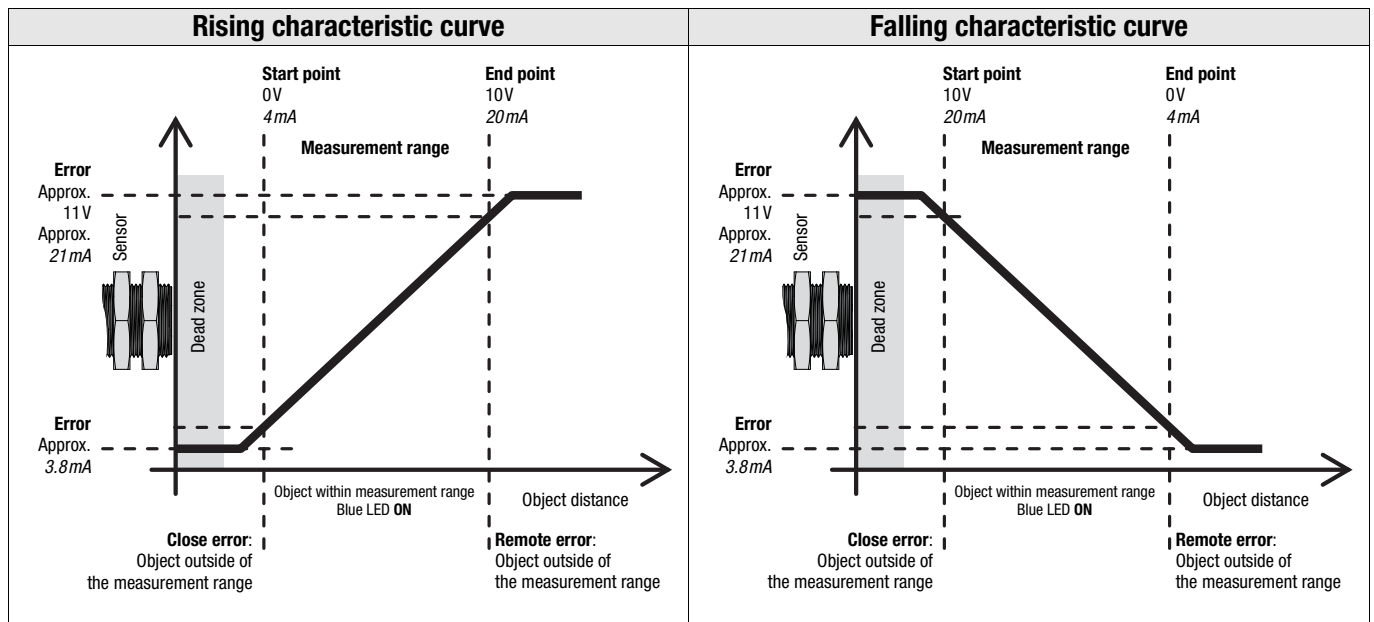

Note!

When setting the analog output (teach) via the teach button, one **rising characteristic curve** is always taught; with 2-point teach, independent of the selected object distances near/far. The characteristic output curve can be inverted, however.

Adjusting the analog output via the teach button

On delivery, the characteristic output curve of the sensor is set as a rising characteristic curve with spread over the entire scanning range: 4 ... 20mA or 0 ... 10V corresponds to an object distance of 250 ... 3500mm or 350 ... 6000mm, respectively.

The analog output can be set by means of 1-point teach or 2-point teach.



Note!

When setting the analog output (teach) via the teach input, one **rising characteristic curve** is always taught; with 2-point teach, independent of the selected object distances near/far. The characteristic output curve can be inverted, however.

Selecting the output that is to be taught: OUT1 or Analog OUT

1. Press the **teach button** for $\geq 2s$ to **activate teach mode**. The **yellow LED (OUT 1)** flashes at 1Hz. While in this state, **output OUT 1** can be taught.
2. To teach **output Analog OUT**, **briefly** press the **teach button** again. The **blue LED (Analog OUT)** now flashes at 1Hz. While in this state, **output Analog OUT** can be taught.
3. Briefly press the teach button again to toggle between outputs **OUT 1** and **Analog OUT** in this state. The flashing LED indicates which output is ready for teaching:
yellow LED flashing = OUT 1 ready for teaching,
blue LED flashing = Analog OUT ready for teaching.

1-point teach of the analog output

First activate the previously described teach mode for output Analog OUT.

By selecting an object distance within the scanning range, the characteristic curve of the analog output can be adjusted.

If an object is located outside of the taught measurement range, an error signal is output. A different analog signal is output here by the sensor for the errors "distance too close: object outside of the measurement range" and "distance too far: object outside of the measurement range".

1-point teach - rising characteristic curve

<p>1. Place object at desired distance for the end point of the measurement range.</p> <p>Note: The minimum object distance for the end of the measurement range is as follows: scanning range of 3500mm:600mm scanning range of 6000mm:950mm</p>
<p>2. To adjust analog output Analog OUT, press the teach button for 2 ... 7s until the blue and green LEDs flash simultaneously at 3Hz.</p>
<p>3. Release the button. The characteristic curve with plot rising from the start of the range (50 mm or 150 mm) to the set object distance was taught in.</p>
<p>4. Error-free teach: LED states acc. to "Technical data" -> "Indicators".</p> <p>Faulty teach: green and blue LEDs flash at 8Hz until an error-free teach is performed.</p>

2-point teach of the analog output

First activate the previously described teach mode for output Analog OUT.

By selecting 2 object distances within the scanning range, the characteristic curve of the analog output can be adjusted.

If an object is located outside of the taught measurement range, an error signal is output. A different analog signal is output here by the sensor for the errors "distance too close: object outside of the measurement range" and "distance too far: object outside of the measurement range".

2-point teach - rising characteristic curve

<p>1. Position the object at the first desired distance (near or far).</p>
<p>2. To adjust analog output Analog OUT, press the teach button for 7 ... 12s until the blue and green LEDs flash alternately at 3Hz.</p>
<p>3. Release the button. The sensor remains in teach mode and the LEDs continue to flash.</p>
<p>4. Then position the object at the second desired distance (far or near).</p> <p>Note: the minimum object distance between the start and end point of the measurement range for a scanning range of 3500mm is:350mm for a scanning range of 6000mm is:600mm</p>
<p>5. Briefly press the teach button again to complete the teach event.</p> <p>The characteristic curve with rising plot from the near to the far object distance was taught in.</p>
<p>6. Error-free teach: LED states acc. to "Technical data" -> "Indicators".</p> <p>Faulty teach: green and blue LEDs flash at 8Hz until an error-free teach is performed.</p>

Inverting the analog output (falling/rising characteristic curve)

First activate the previously described teach mode for output Analog OUT.

The characteristic curve of the analog output can be inverted, e.g., if a falling characteristic output curve is desired.

Inverting the characteristic curve

<p>1. To invert the characteristic curve of the analog output Analog OUT, press the teach button for > 12s until the blue and green LEDs flash alternately.</p>
<p>2. Release the button. The characteristic curve plot was inverted.</p> <p>The blue LED indicates the current setting of the analog output:</p> <p>ON = rising characteristic curve</p> <p>OFF = falling characteristic curve</p>

DMU330

Ultrasonic sensors with analog and switching output

Synchronization of multiple DMU330 ultrasonic sensors

If adjacent ultrasonic sensors receive the signals of other sensors, so-called crosstalk occurs, which leads to faulty measurement results. Through temporal synchronization of the adjacent sensors, this can be avoided. Via the **Sync/MUX** input, the DMU330 ultrasonic sensors can be synchronized in 2 different ways:

Synchronous operation

In this operating mode the mutual interference of adjacent sensors can be avoided; a minimum mounting distance between the sensors is to be maintained, however:

Working distance	Minimum mounting distance
< 1,500mm	100mm
≥ 1500mm	50mm

Sensors of the same type are wired together in a network according to the following diagram. A synchronization pulse from the control activates synchronous operation.

The devices work in synchronous operation with a **simultaneous transmission pulse**. The response time of the individual sensors in the network corresponds approximately to that of a single sensor.

Synchronous operation wiring schematic

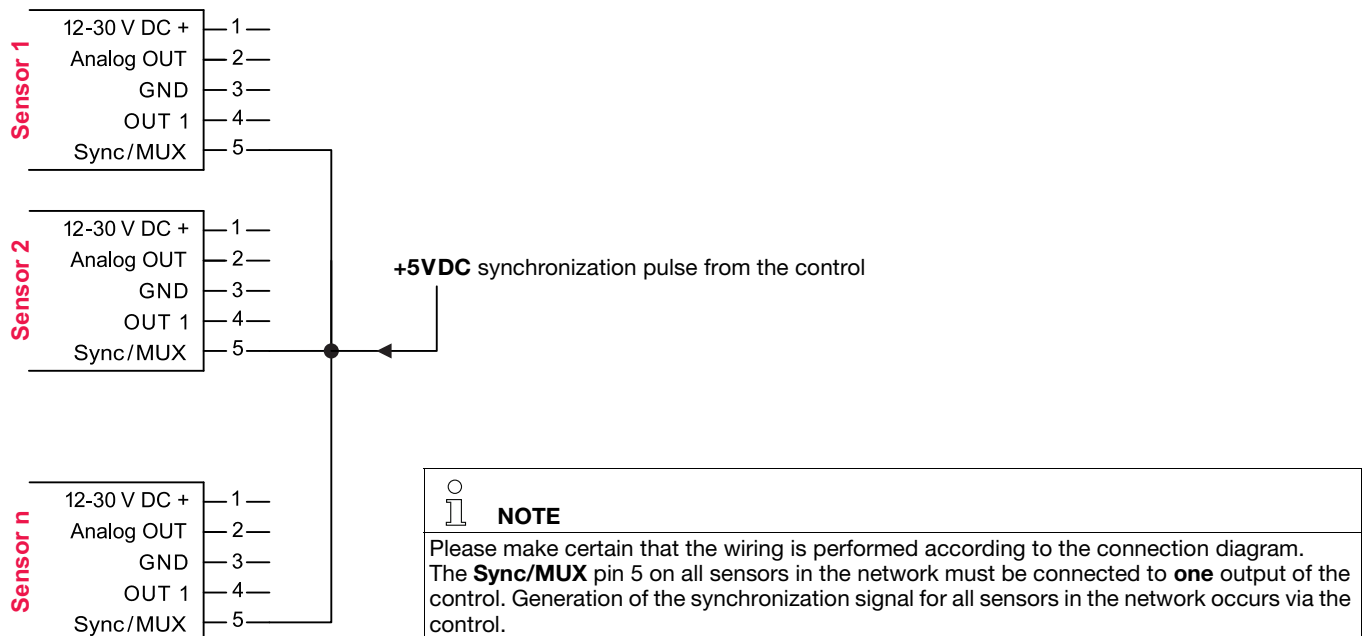

Timing diagram for synchronous operation

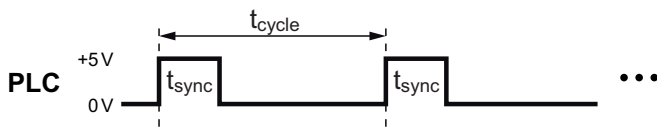

Scanning range	Sync impulse duration t_{sync}	Cycle time t_{cycle}
250 ... 3500mm	0.5 ... 5ms	35ms
350 ... 6000mm	0.5 ... 1ms	60ms

Multiplex operation

In this operating mode the mutual interference of adjacent sensors can be reliably avoided. For this purpose, each sensor is wired with a separate output of the control.

The devices operate in multiplex operation with a **cyclically time-delayed transmission pulse** and are switched to a passive state outside of the active phase.

Multiplex operation wiring schematic

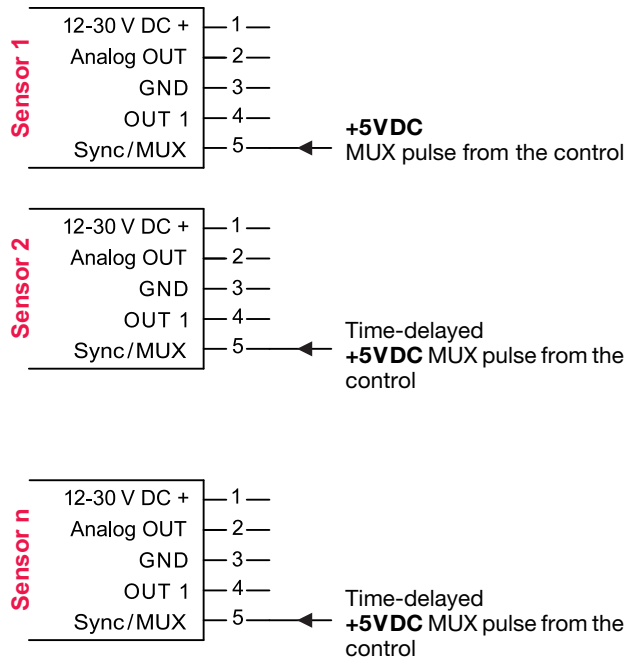

NOTE
Please make certain that the wiring is performed according to the connection diagram.
The **Sync/MUX** pin 5 of each sensor must be connected with a separate output of the control.
The control generates the time-delayed multiplex signals for all sensors.

Timing diagram for multiplex operation

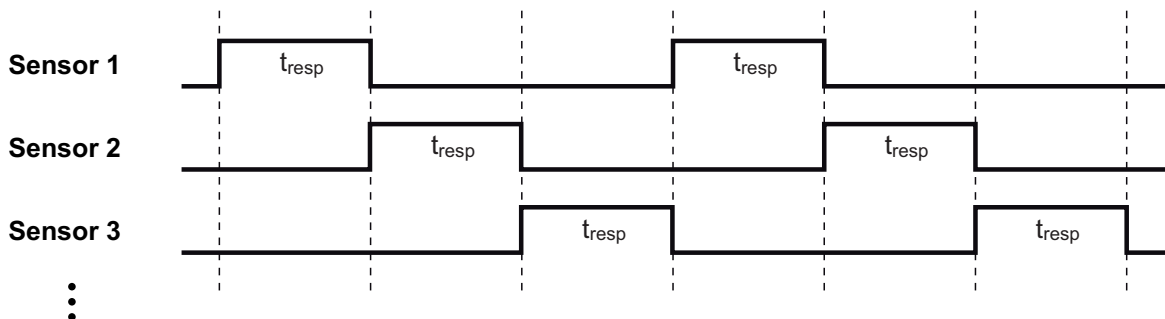

Scanning range	Response time of the switching/analog output t_{resp}
250 ... 3500mm	250ms
350 ... 6000mm	500ms

Resetting to factory settings

The sensor can be reset to the factory setting (1 switching point at 3500mm or 6000mm, rising characteristic curve with spread over the entire scanning range).

Resetting to factory settings
1. When switching on the supply voltage (during power-on), press the teach button for > 5s.
2. Release the button. The green, yellow and blue LEDs flash alternately and very quickly for a brief time. The sensor was reset to the factory setting: switching output: 1 switching point at 3500mm or 6000mm (1-point teach, static), analog output: 4 ... 20mA or 0 ... 10V corresponds to an object distance of 250 ... 3500 mm or 350 ... 6000 mm, respectively.